

# Twist Still

## Customizable Flavored Enhanced Water System

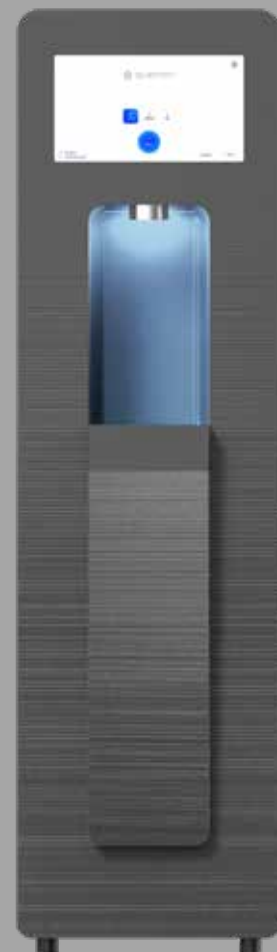

- Cold, ambient, or hot water with optional flavor enhancements
- Beautiful and intuitive 15.35" touchscreen for effortless dispensing
- User-selected flavors and flavor combinations with control over flavor intensity to create your own custom beverage
- Natural sweetener added at user's preference to boost and brighten flavor profile
- Remote system monitoring allows proactive service support from Culligan Quench
- State-of-the-art filtration provides clean, great-tasting drinking water on-demand
- Point-of-dispense UVC LED dispensing protection technology



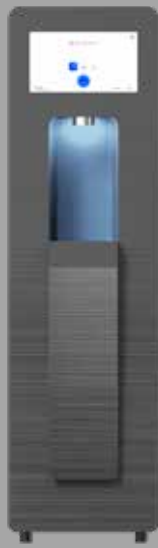

## Specifications

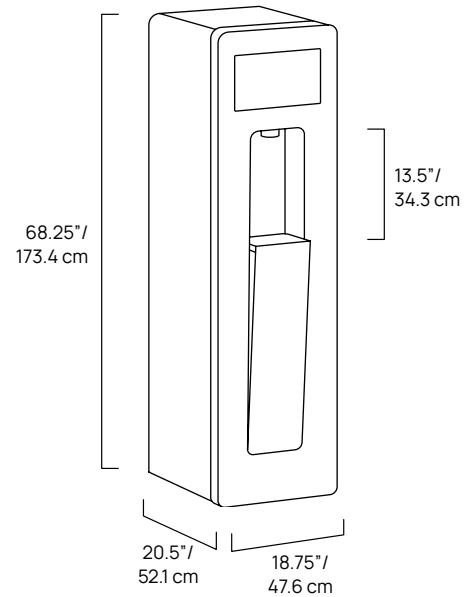

## Product Details

Elevate your hydration experience with the sleek and modern Twist Still! This new Enhanced Water System offers cold, ambient, or hot water with optional flavor selections, making it ideal for any breakroom, customer waiting area, or workplace cafeteria. The beautiful and intuitive touchscreen allows users to effortlessly customize flavor intensity, create flavor combinations, and adjust sweetener strength while counting 12 oz. bottles saved. With advanced multi-stage filtration and UVC LED protection at the point of dispense, you can count on always having the highest quality water. Plus, remote system monitoring provides proactive service support. Enjoy sustainable, great-tasting, customizable water with the Twist Still!

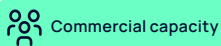

### Refreshing Flavored and Enhanced Water with the Twist Still

- Cold, ambient, and hot filtered water
- 8 zero-calorie, fruit-inspired flavors available and 1 Stevia sweetener
- State of the art 15.5" dynamic color touchscreen for effortless customization of the 4 installed flavor and sweetener enhancements
- Large 13.25" dispensing area perfect for most reusable bottles
- Advanced filtration to produce clean, great-tasting drinking water on-demand
- Point-of-dispense UVC LED dispensing protection technology
- User-friendly design with remote system monitoring for easy replenishment of flavors and enhancements and proactive service support and protection
- Drink capture feature to track users most used flavors and sweetener usage

Dimensions	68.25" h x 18.75" w x 20.5" d / 173.4 cm h x 47.6 cm w x 52.1 cm d Cord/water connection add 3" (7.6 cm) to depth
Dispensing Area Height	13.5" / 34.3 cm
Screen size	15.35" / 39 cm
Weight	230 lbs / 104.3 kg
Cold Tank Capacity	20 gal/hr / 75.7 liters/hr
Hot Tank Capacity	0.4 gal / 1.5 liters
Water Pressure	50-80 PSI
Power Consumption	7.5A
Rated Voltage/Frequency	115V/60Hz
Model Number	820

### Flavors

- Watermelon
- Pineapple Strawberry
- Cucumber
- Peach Mango
- Pomegranate Blueberry
- Cherry Lime
- Mixed Berry
- Lemon
- Natural Sweetener Made with Stevia Extract
- *More flavors and enhancements coming soon*

Culligan Quench products are certified by independent authorized 3rd party laboratories in accordance with appropriate industry standards. To find out more about which certifications your product may have, please contact us.