

Culligan. quench®

# Twist Sparkling

Customizable Flavored Enhanced Sparkling Water Dispenser



- Cold, ambient, hot, and chilled sparkling water with optional flavor enhancements
- Beautiful and intuitive 15.35" touchscreen for effortless dispensing
- User-selected flavors and flavor combinations with control over flavor intensity to create your own custom beverage
- Natural sweetener added at user's preference to boost and brighten flavor profile
- Remote system monitoring allows proactive service support from Culligan Quench
- State-of-the-art filtration provides refreshing, great-tasting drinking water on-demand
- Point-of-dispense UVC LED dispensing protection technology

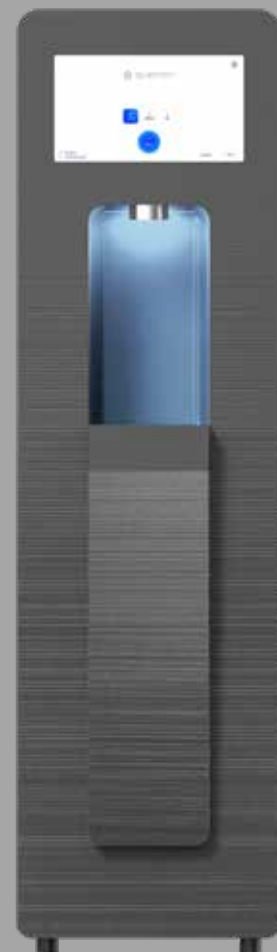

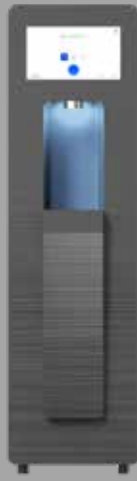

## Specifications

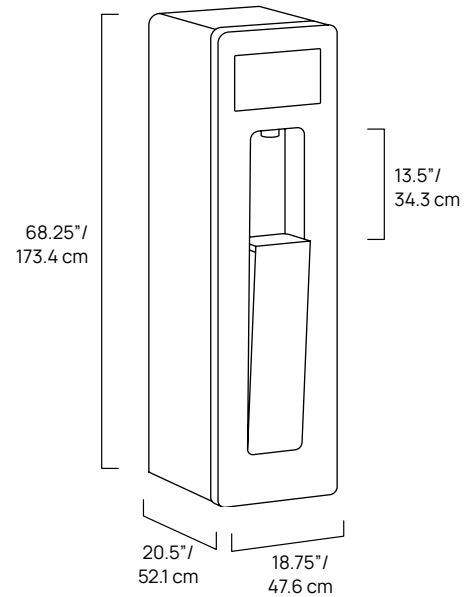

## Twist Sparkling

Elevate hydration with the Twist Sparkling! This sleek, new Enhanced Water System offers cold, ambient, hot, or chilled sparkling water with optional flavor selections, making it a healthier, sustainable, and cost-effective alternative to traditional sodas. Perfect for any breakroom, customer waiting area, or workplace cafeteria, the Twist Sparkling provides a refreshing pick-me-up, boosting energy and productivity. The beautiful and intuitive touchscreen allows users to effortlessly customize flavor intensity, create flavor combinations, adjust sweetener strength, and select their preferred sparkling level while counting 12 oz. bottles saved. With advanced multi-stage filtration and UVC LED protection at the point of dispense, you can always count on the highest quality water. Plus, remote system monitoring ensures proactive service support. Enjoy crisp, customizable sparkling water effortlessly with the Twist Sparkling.



### Enjoy Flavored and Enhanced Sparkling Water with the Twist Sparkling

- Cold, ambient, and hot filtered water
- Chilled sparkling filtered water
- 8 zero-calorie, fruit-inspired flavors available and 1 Stevia sweetener
- State of the art 15.5" dynamic color touchscreen for effortless customization of the 4 installed flavor and sweetener enhancements
- Large 13.25" dispensing area perfect for most reusable bottles
- Advanced multi-stage filtration to produce refreshing, great-tasting drinking water on-demand
- Point-of-dispense UVC LED dispensing protection technology
- Typically fits 20 lb. CO2 cylinder inside the machine
- User-friendly design with remote system monitoring for easy replenishment of flavors and enhancements and proactive service support and protection
- "Drink capture" feature to track your users most used flavors and sweetener usage

Dimensions 68.25" h x 18.75" w x 20.5" d  
173.4 cm h x 47.6 cm w x 52.1 cm d  
Cord/water connection add 3" (7.6 cm) to depth

Dispensing Area	13.5" / 34.3 cm
Screen size	15.35" / 39 cm
Weight	230 lbs / 104.3 kg.
Cooling Capacity	20 gal/hour / 75.7 liters/hour
Hot Tank Capacity	0.4 gallon/1.5 liters
Recommended Water Pressure	50-80 PSI
Rated Voltage/Frequency	115V / 60Hz
Power Consumption	7.5A
Model Number	830

### Flavors

- Watermelon
- Pineapple Strawberry
- Cucumber
- Peach Mango
- Pomegranate Blueberry
- Cherry Lime
- Mixed Berry
- Lemon
- Natural Sweetener Made with Stevia Extract
- *More flavors and enhancements coming soon*

Quench products are certified by independent authorized 3rd party laboratories in accordance with appropriate industry standards. To find out more about which certifications your product may have, please contact us.