

90 Series Pre-Installation Checklist

Thank you for being a Culligan Quench customer! We are excited for your workplace to experience the great-tasting sparkling water from your new 90 series machine. Before our certified technician can install your machine, the following pre-installation requirements must be completed.

Water Supply

- 3/8" potable water supply line terminating in standard plumbing fitting (must be accessible for service and installation)
- Minimum water supply pressure 14.5 PSI, 1 gallon per minute minimum flowrate
 - Must be a dedicated 3/8" water supply line with no other connections
 - Any water line or valve less than 3/8" is not acceptable

Electrical

- Dedicated 115 VAC/60 Hz/15 amp (NEMA 5-15R) electrical circuit
 - GFCI receptacle or circuit is required
- Electrical connections within 40" of machine location; **NO EXTENSION CORDS**

Ventilation

- Clean, dry, well-ventilated area from any source of heat; Ambient temperature must be between: 41°F - 107.6°F
- 4-inches of clearance around each side of the machine
- If installed in an enclosed space, adequate ventilation must be provided.
 - Customer may elect to have a cabinet/casework contractor install vents with grills or grates
 - Culligan Quench technicians can drill six (6) 1.5" diameter holes in one side and the bottom of the cabinet to allow adequate airflow

Countertop Tap Placement

- 1.5" diameter hole for the tap head mounting
 - Culligan Quench technicians are only permitted to drill up to 2" diameter holes through laminate or Corian counters. Any other surface or hole size must be pre-drilled prior to install.
- Clearance above the tap to accommodate the usage of the tap (tap is 20" tall, recommend additional 6" clearance)
- The tap must be installed directly above the machine

CO2 Supply

- CO2 cylinder is on-site
 - If connecting to a bulk or existing CO2 system, a CO2 line terminating at a 3/8" barbed shutoff valve must be available within 40" of the installation site
 - Minimum CO2 pressure is 58 PSI

If you have any questions about the installation, call Customer Care at 888-554-2782



Installation Configuration Diagram

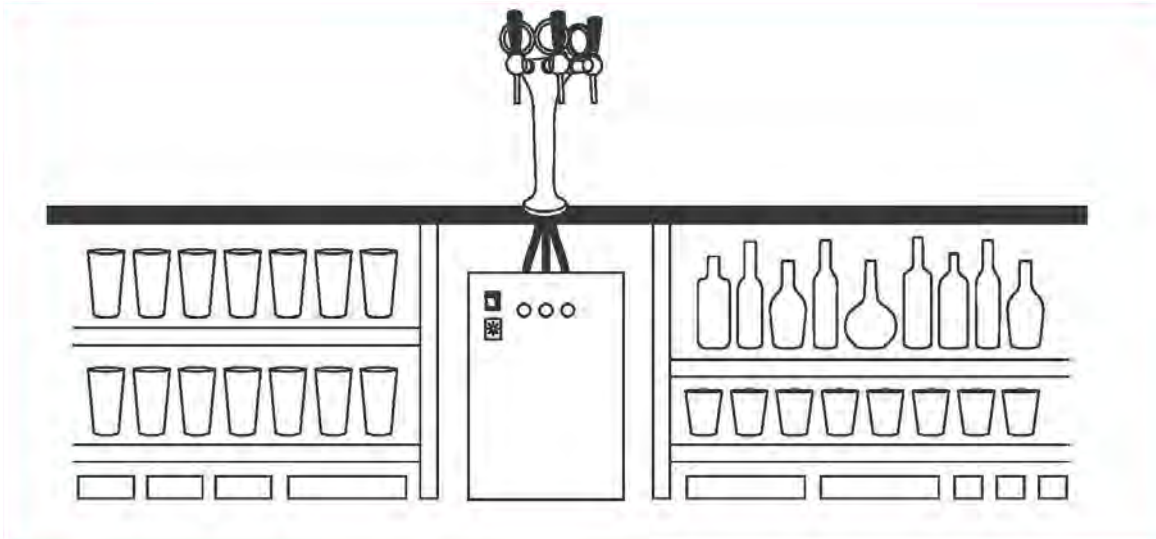

Tap Head Measurements

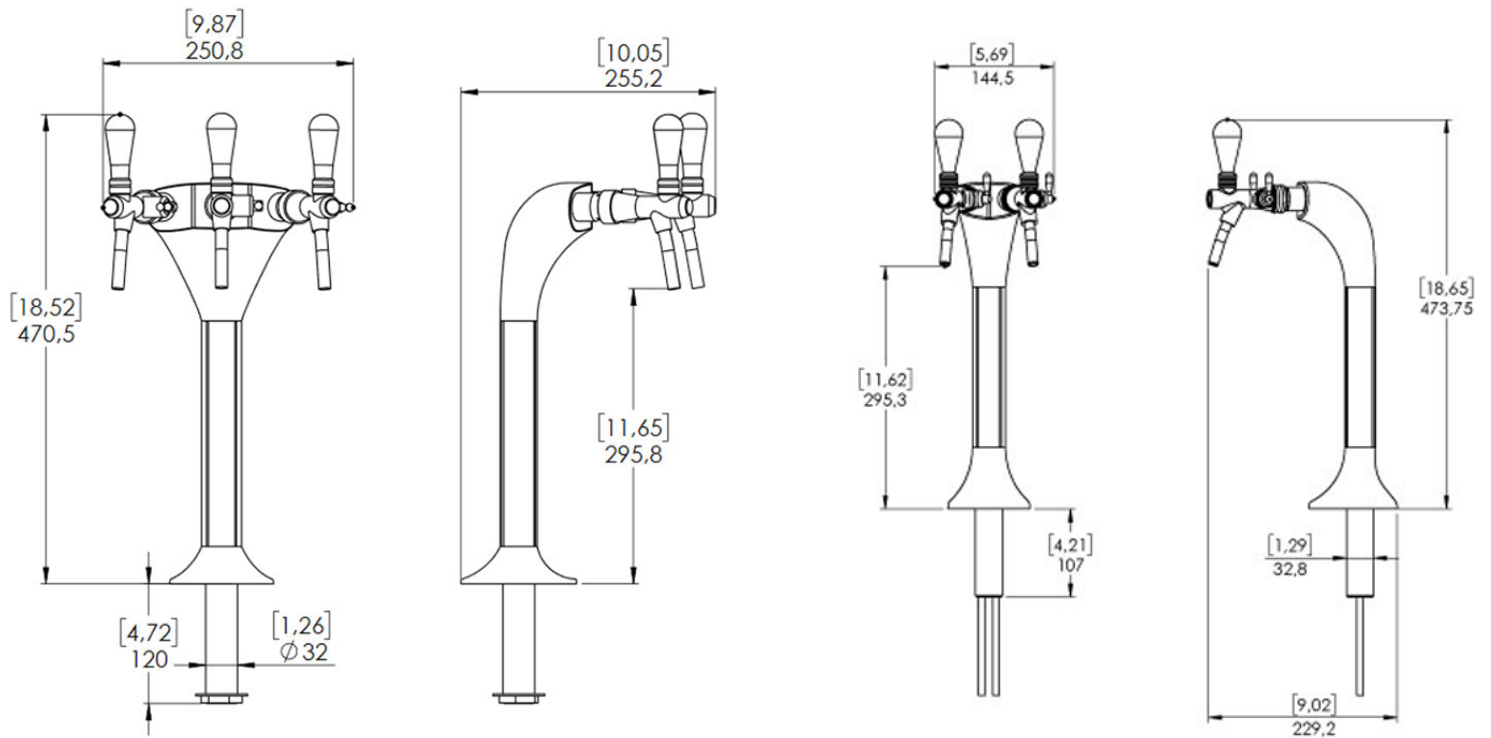

Talk to your dedicated
Culligan Quench Water
Expert.

Phone
844-557-8320

Website
www.culliganquench.com