



Tower 70

Sparkling Water Dispenser

- Cold and ambient filtered water
- Chilled sparkling water
- Two-tap or three-tap dispensing
- Easy-to-use tap dispensing with bottle filling capabilities
- Vero+ advanced filtration
- Ice bank chilling technology with R290 refrigerant to keep up with demand
- 48 reusable Vero glass bottles provided



Culligan quench





Tower 70

The Vero Water Tower 70 is a filtered still and sparkling water system that produces 180 liters of chilled still or sparkling water in an hour* – perfect for restaurants, hotels, and bars. The Vero Water Tower 70 uses EPA recommended R290 refrigerant, which is natural, non-toxic, and free of ozone-depleting properties, because it is one of the most climate-friendly refrigerants available. The Vero Water Tower 70's 11" dispense height with drip tray, rapid chilling, and manual portion control makes bottle-filling with Vero's exclusive reusable glass bottles an easy task for any staff or guest. Install the Vero Water Tower 70 to transfer your guests' hydration experience!

Sparkling Water On-Demand

- Freshly chilled still and sparkling water through ice bank chilling technology
- Vero-branded two-tap dispensing features cold and sparkling water
- Chrome three-tap dispensing features cold, ambient, and sparkling water
- Chills up to 180 liters of filtered water in an hour*
- Dispensing height of 11" to accommodate exclusive Vero glass bottles
- 48 reusable Vero glass bottles included
- Installed and pre-regulated with backflow prevention
- Easily connects to either external CO2 tank or bulk CO2 supply
- Countertop mounted drip tray can be installed as optional recessed drain tray for plumbed in drain

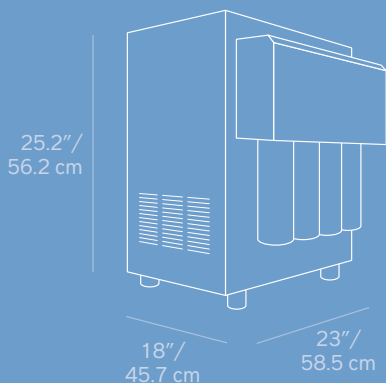
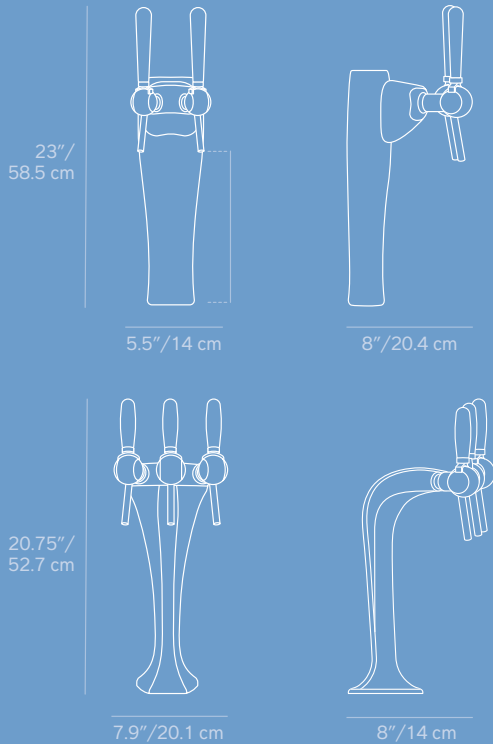

2-Tap Tower Dimensions	23" h x 5.5" w x 8" d / 58.5 cm h x 14 cm w x 20.4 cm d Depth is 12" when taps are in use.
3-Tap Tower Dimensions	20.75" h x 7.9" w x 8" d / 52.7 cm h x 20.1 cm w x 20.4 cm d Depth is 11" when taps are in use.
Drip tray dimensions	1" h x 12.25" w x 7.5" d / 2.6 cm h x 31.1 cm w x 19.1 cm d
Undercounter dimensions	25.2" h x 18" w x 23" d / 56.2 cm h x 45.7 cm w x 58.5 cm d Width includes 4.25" width for the filtration housing
Ventilation clearance requirement	2" / 5 cm on all sides and top
Dispense height	11" / 28 cm
Tower dry weight	20 lbs. / 9.1 kg
Undercounter dry weight	94 lbs. / 42.7 kg
Water options	Cold still and chilled sparkling or cold still, ambient still, and chilled sparkling water
Chilling capacity	180 liters in an hour*
Cooling technology	Ice Bank chilling technology with R290 refrigerant
Recommended water pressure	50 psi
Ice block weight	22 lbs / 10 kg
CO2 specification	Available external CO2 tank or bulk CO2 supply connection; Runs at 55 PSI
Rated voltage/frequency/ running amps	115 V / 60 Hz / 7 amps
Model number	Vero Water Tower 70-2 taps or Vero Water Tower 70-3 taps

* Chilling capacity may vary depending on ambient water temperature.

All products are certified by independent authorized 3rd party laboratories in accordance of appropriate industry standards. To find out more about which certification your product may have, please contact us.

877.727.8376 | quenchwater.com

© 2023 Culligan Quench. All rights reserved. VInspire-001-OCT23

Culligan quench