

# Q9

## High-Capacity Bottlefree Water Cooler with Firewall®



- Bottlefree high-capacity water cooler with bottle saver counter
- Cold, ambient, hot, and extra hot filtered drinking water on-demand
- Interactive full color LED display with touch button dispensing
- Optional touchless interface available
- BioCote® antimicrobial surface protection technology
- Firewall® UV-C technology at the point of dispense for better water quality and system cleanliness





## Specifications

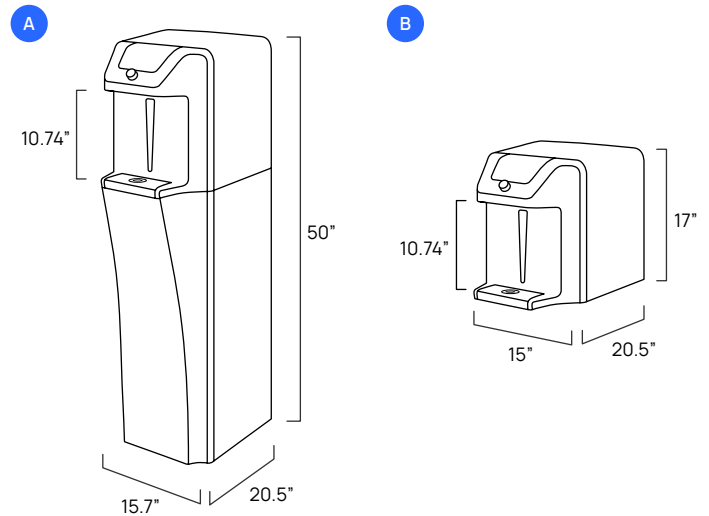

## Product Details

Elevate your water cooler with the Q9 with Firewall®! The Q9 offers enough cold, ambient, hot and extra hot filtered water on-demand for any office, breakroom, or high-traffic area. The Q9 takes cleanliness to the next level with BioCote® antimicrobial surface protection to control microbial growth on key surfaces as well as patented Firewall® UV-C technology at the point of dispense to maintain water cleanliness. The Q9 features a programmable energy saving sleep mode to reduce power consumption and bottles saved counter to track the environmental impact of usage. The Q9 is available as an ergonomically designed freestanding machine or space-saving compact countertop machine.

 Large capacity

### Advanced Features

- State-of-the-art filtration to produce clean, great-tasting drinking water on-demand
- Dispenses an immense supply of cold, ambient, hot, and extra hot drinking water
- Interactive full color LED display with dial dispensing
- Large dispensing area for easy water bottle filling with generous drip tray
- Firewall® UV-C system that maintains water cleanliness at point of dispensing
- BioCote® antimicrobial surface protection
- Bottles saved counter to track 16 oz. plastic bottles saved from users
- Filter and UV fault indicators as well as leak prevention system
- Optional touchless interface available

### A Q9 Freestanding

Dimensions	50" h x 15.7" w x 20.5" d
Dispensing Area Height	10.74"
Weight	103 lbs.
Cold Tank Capacity	4.5 gal/hour
Hot Tank Capacity	0.4 gal
Water Pressure	40 – 60 psi
Rated Voltage/Frequency	120V/60Hz
Model Number	Q9 FS

### B Q9 Countertop

Dimensions	17" h x 15" w x 20.5" d
Dispensing Area Height	10.74"
Weight	66 lbs.
Cold Tank Capacity	4.5 gal/hr
Hot Tank Capacity	0.4 gal
Water Pressure	40 – 60 psi
Rated Voltage/Frequency	120V/60Hz
Model Number	Q9 CT

Culligan Quench products are certified by independent authorized 3rd party laboratories in accordance with appropriate industry standards. To find out more about which certifications your product may have, please contact us.