

# Q5

## Freestanding and Countertop Series with quenchWATER+



- Bottlefree, large capacity water cooler
- Delivers quenchWATER+ mineral-enhanced and electrolyte-infused water
- Protects from contamination with advanced
- filtration and UV light technology





# Specifications

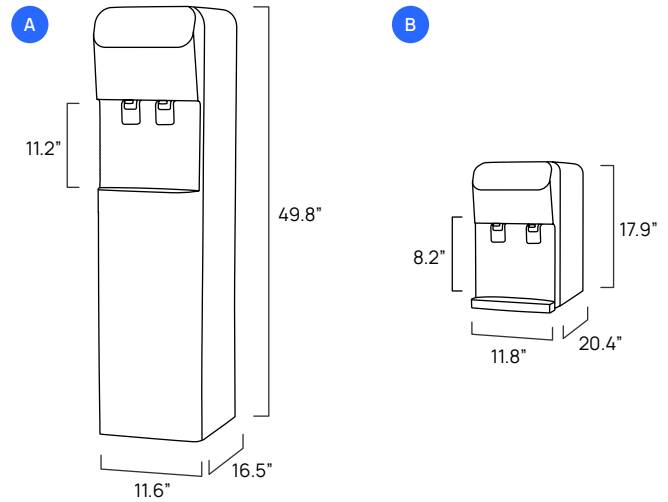

## Product Details

The Q5 series will level up all break rooms by providing quenchWATER+ alkaline drinking water from a state-of-the-art bottle-free water cooler. The Q5's advanced filtration system removes contaminants from the water and then adds back essential electrolytes and minerals to improve water taste, producing quenchWATER+ drinking water. The in-tank UV light and antimicrobial surface protection offer distinct water quality assurance.

Large capacity

Mineral+

### Advanced Features

- Reverse osmosis or carbon filtration with mineral additives to produce quenchWATER®\*
- LED ultraviolet light to maintain water quality
- Rugged paddle dispensing and hot water safety feature
- Antimicrobial surface protection
- Taller ergonomic “no-bend” dispensing design (Freestanding model)
- quenchWATER+ system fits nicely inside (Freestanding model)
- Fits under most cabinets (countertop model)

### A Q5 Freestanding

Dimensions 49.8" h x 11.6" w x 16.5" d / 127 cm h x 30 cm w x 42 cm d

quenchWATER+ filtration system is installed in base of machine and no RO tank is required for most installations

Dispensing Area Height	11.2"
Weight	60 lbs/28 kg
Cold Tank Capacity	1.6 gallons/6.1 liters
Hot Tank Capacity	0.7 gallons/2.7 liters
Filtration	quenchWATER+ RO or CF
Recommended Water Pressure	40 – 60 psi
Power Consumption	1.6kWh/24 hours
Rated Voltage/Frequency	120V/60Hz
Model Number	Q5FS RO QW plus/Q5FS CF M plus

### B Q5 Countertop

Dimensions 17.9" h x 11.8" w x 20.4" d / 46 cm h x 30 cm w x 51.8 cm d

quenchWATER+ filtration system is installed in machine.

RO tank may be required for installation.

RO tank – 10.9" diameter x 13.75" h/28 cm diameter x 35 cm h

Dispensing Area Height	8.2"
Weight	49 lbs/23 kg
Cold Tank Capacity	1.0 gallons/3.8 liters
Hot Tank Capacity	0.4 gallons/1.4 liters
Filtration	quenchWATER+ RO or CF
Recommended Water Pressure	40 - 60 psi
Power Consumption	1.1 kWh/24 hours
Rated Voltage/Frequency	120V/60Hz
Model Number	Q5CT RO QW plus/Q5CT CF M plus

\* Essential minerals including calcium, magnesium, potassium, and sodium are added to the water to give it a crisper mineral water taste. The mineral filter media has FDA- and other third party certifications and the quantities of minerals added are negligible such that they are considered insignificant in a diet context. The Q5 is certified by IAPMO R&T according to NSF/ANSI 372 standards. For more information, please contact us.