

# Q10

## Bottlefree Water Cooler with Sparkling with Firewall® Protection



- Bottlefree high-capacity water cooler
- Cold, ambient, hot, and extra hot filtered drinking water on-demand
- Chilled sparkling water
- Interactive full color LED display with dial dispensing
- Optional touchless interface available
- BioCote® antimicrobial surface protection technology
- Firewall® UV-C technology at the point of dispense for better water quality and system cleanliness





## Specifications

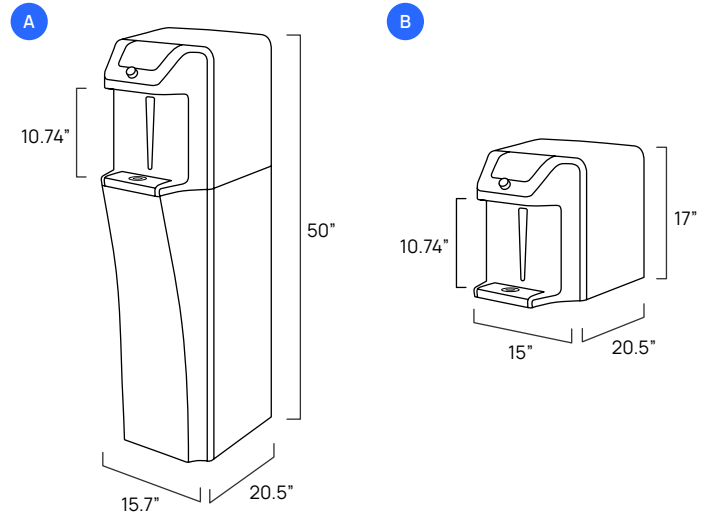

## Product Details

Level up your office hydration with a Q10 Bottleless Water Cooler with Sparkling Water! This stylish water cooler provides cold, ambient, hot or extra hot water on-demand as well as chilled sparkling water to satisfy any hydration request in the office. Using proprietary Firewall® UV-C technology at the point of dispense and state-of-the-art filtration technology, the Q10 purifies drinking water on-demand, providing a continuous supply of great-tasting, clean still or sparkling water. The Q10 continues to control microbial growth through BioCote® antimicrobial surface protection on key surfaces. The Q10 also features a bottle saver counter to track the number of 16 oz. plastic bottles your users save each time they fill their glass. The Q10 is available in a freestanding model or as space-saving countertop model.

 Large capacity

### Advanced Features

- State-of-the-art filtration produces clean, great-tasting drinking water on-demand
- Dispenses a continuous supply of cold, ambient, hot and extra hot drinking water as well as chilled sparkling water
- Interactive full color LED display with dial dispensing
- Large dispensing area for easy water bottle filling with generous drip tray capacity
- Firewall® UV-C purification system at the point of dispense to maintain water and system cleanliness
- BioCote® antimicrobial surface protection
- Filter and UV fault indicators as well as leak prevention system
- Optional touchless interface dispensing

### A Q10 Freestanding

Dimensions	50" h x 15.7" w x 20.5" d
Dispensing Area Height	10.74"
Weight	103 lbs.
Cold Tank Capacity	4.0 gal/hr
Sparkling Water Capacity	3.7 gal/hr
Hot Tank Capacity	0.4 gal
Water Pressure	40 – 60 psi
Rated Voltage/Frequency	120V/60Hz
Model Number	Q10 FS

### B Q10 Countertop

Dimensions	17" h x 15" w x 20.5" d
Dispensing Area Height	10.74"
Weight	66 lbs.
Cold Tank Capacity	4.0 gal/hr
Sparkling Water Capacity	3.7 gal/hr
Hot Tank Capacity	0.4 gal
Water Pressure	40 – 60 psi
Rated Voltage/Frequency	120V/60Hz
Model Number	Q10 CT

Culligan Quench products are certified by independent authorized 3rd party laboratories in accordance with appropriate industry standards. To find out more about which certifications your product may have, please contact us.