

998

Commercial Bin Ice Machine



- Produces up to 575 lbs of half-dice ice in a day
- Ice storage of 532 lbs
- Programmable ice production
- Intelligent diagnostics for trouble-free operation
- Stainless steel finish resists fingerprints and dirt





Specifications

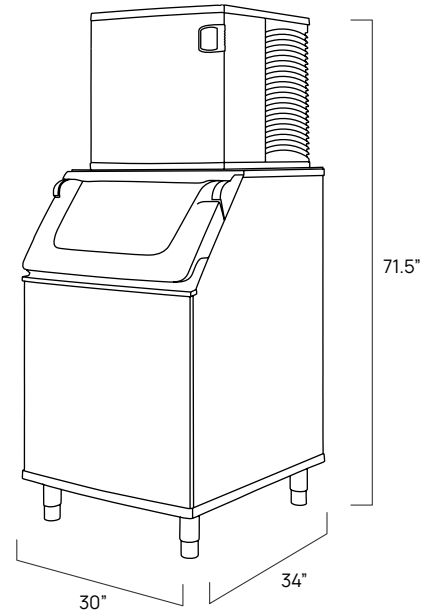

Product Details

Upgrade your bin ice machine with the 998! This space-saving compact bin ice machine delivers up to 575 pounds of half-dice ice a day while storing 532 pounds. The 998 offers state-of-the-art diagnostic technology for dependable operation and ice production monitoring. The 998's stainless steel finish resists fingerprints and dirt for easy cleaning.

 Commercial capacity

Commercial Bin Ice Machine

- Produces up to 575 lbs of half-dice ice
- Ice storage of up to 532 lbs
- Programmable ice production and bin level control with LED display
- State-of-the-art carbon or reverse osmosis filtration
- Luminice™ bacteria inhibitor
- Intelligent diagnostics for trouble-free operation
- Stainless steel finish resists finger prints and dirt

Dimensions	71.5" h x 30" w x 34" d
Weight	258 lbs
Ice Output	Up to 575 lbs/24 hours
Ice Storage	532 lbs
Recommended Water Pressure	20 - 80 psi
Electrical Requirement	Dedicated 115-120V/15 amp circuit
Power Consumption	4.87 kW/100 lbs of ice production
Drain Requirement	Needs to be installed within 10 feet of a drain
Water Consumption	20 gal/100 lbs of ice production
Clearance	12" top, 12" sides, 5" back
Model Number	998

Culligan Quench products are certified by independent authorized 3rd party laboratories in accordance of appropriate industry standards. To find out more about which certifications your product may have, please contact us.

* Ice production can change based on source water and ambient air temperature.