

Culligan. quench®

994

High-Capacity Bin Ice Machine



- State-of-the-art filtration technology
- Produces up to 575 lbs of half-dice ice in a day
- Ice storage of 383 lbs
- Programmable ice production
- Intelligent diagnostics for trouble-free operation
- Space-saving design





Specifications

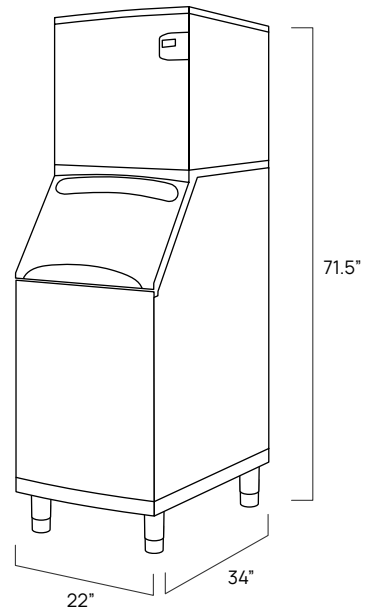

Product Details

Level up your bin ice machine with the 994! This space-saving bin ice machine delivers up to 575 pounds of half-dice ice a day and stores up to 383 pounds. The 994 offers state-of-the-art diagnostic technology for dependable operation and ice production monitoring. This bin ice machine is ideal for low-clearance spaces or built-in applications.

 Commercial capacity

High-Capacity Bin Ice Machine

- Produces up to 575 lbs of half-dice ice
- Ice storage of up to 383 lbs
- Programmable ice production and bin level control with LED display
- State-of-the-art carbon or reverse osmosis filtration
- Luminice™ bacteria inhibitor
- Intelligent diagnostics for trouble-free operation
- Stainless steel finish resists finger prints and dirt

Dimensions	71.5" h x 22" w x 34" d
Weight	253 lbs
Ice Output	575 lbs/24 hours
Ice Storage	383 lbs
Recommended Water Pressure	20 - 80 psi
Electrical Requirement	Dedicated 115V/20 amp breaker
Power Consumption	4.87 KW/100 lbs of ice production
Drain Requirement	Needs to be installed within 10 feet of a drain
Water Consumption	19.9 gal/100 lbs of ice production
Clearance	12" top, 12" sides, 5" back
Model Number	994

Culligan Quench products are certified by independent authorized 3rd party laboratories in accordance of appropriate industry standards. To find out more about which certifications your product may have, please contact us.

* Ice production can change based on source water and ambient air temperature.