

Culligan. quench®

# 980-50/ 985-50

## Commercial Capacity Water and Ice Dispenser



- Room temperature water
- Produces up to 425 lbs of chewable compressed nugget ice in 24 hours
- Stores up to 50 lbs of ice
- State-of-the-art filtration technology
- Sanitary touchless dispensing
- Antimicrobial surface protection





## Specifications

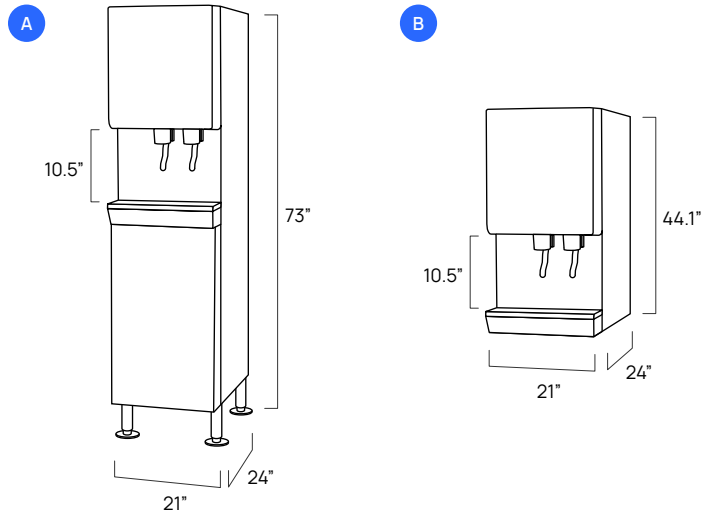

## Product Details

Level up your ice storage with the 980-50! The 980-50 is a commercial capacity ice and water dispenser that produces up to 425 pounds of chewable nugget ice in one day while storing up to 50 pounds. The 980-50 also features a large dispensing area with touchless dispensing. The 985-50 is the same machine as a space-saving countertop model.

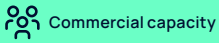

Commercial capacity

### High-Capacity Water and Ice Dispenser

- Chewable Chewlet® ice maker and room temperature water dispenser
- Total ice-making capability – up to 425 pounds per day
- Stores up to 50 lbs of ice
- Advanced carbon or reverse osmosis filtration
- Antimicrobial surface protection
- Large dispensing area with lever dispensing
- Available with SensorSAFE infrared touchless dispensing technology

Culligan Quench products are certified by independent authorized 3rd party laboratories in accordance of appropriate industry standards. To find out more about which certifications your product may have, please contact us.

\* Ice production can change based on source water temperature and ambient air temperature.

### A 980-50 (Freestanding)

Dimensions	73" h x 21" w x 24" d
Dispensing Area	10.5"
Weight	298 lbs
Ice Output	Up to 425 lbs/24 hr
Ice Storage	50 lbs
Recommended Water Pressure	10 - 70 psi
Rated Voltage/Frequency	115v/60Hz @ 13 amps
Power Consumption	5.7 kW/100 lbs of ice
Drainage	Needs to be installed within 10 feet of a drain
Clearance	3" top, 3" right side
Model Number	980-50

### B 985-50 (Countertop)

Dimensions	44.1" h x 21" w x 24" d Height includes optional 4.1" legs
Dispensing Area	10.5"
Weight	188 lbs
Ice Output	Up to 425 lbs/24 hr
Ice Storage	50 lbs
Recommended Water Pressure	10 - 70 psi
Rated Voltage/Frequency	115v/60Hz @ 13 amps
Power Consumption	5.7 kW/100 lbs of ice
Drainage	Needs to be installed within 10 feet of a drain
Clearance	3" top, 3" right side
Model Number	985-50