

905

Undercounter Bin Ice Machine



- High capacity ice making of up to 220 lbs/day
- Ice storage of 90 lbs
- Clear half-dice ice cubes
- Space-saving undercounter design
- Intelligent diagnostics for trouble-free operation
- Programmable ice production
- State-of-the-art filtration





Specifications

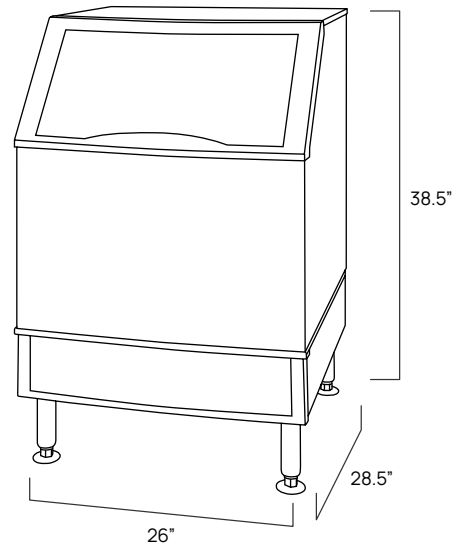

Product Details

Level up your undercounter bin ice machine with the space-saving 905! The 905 delivers up to 220 pounds of clean, clear ice every day with 90 pounds of storage space. The 905's intelligent diagnostics offers trouble-free, dependable operations and ice production monitoring. The 905 compact design and fingerprint resistant stainless-steel finish offers easy access for cleaning and service.

 Commercial capacity

Contemporary Design with Advance Features

- Space-saving undercounter design
- High-capacity ice production of up to 220 lbs/day
- Ice storage of up to 90 lbs
- State-of-the-art filtration
- Intelligent diagnostics for trouble-free operation
- Programmable ice production and bin level control
- Stainless steel finish resists finger prints and dirt
- Luminice™ bacteria inhibitor
- Easy access for cleaning and service
- Reverse osmosis filtration (optional)

Dimensions	38.5" h x 26" w x 28.5" d
Weight	158.7 lbs
Ice Output	220 lbs/24 hours
Ice Storage	90 lbs
Recommended Water Pressure	20 - 80 psi
Electrical Requirement	Dedicated 110V - 120V/15amp breaker
Power Consumption	7.8 kWh/100 lbs of ice production
Water Consumption	16 gal/100 lbs of ice production
Drain Requirement	Needs to be installed within 10 feet of a drain
Clearance	5" top, 5" sides, 5" back
Model Number	905

Culligan Quench products are certified by independent authorized 3rd party laboratories in accordance of appropriate industry standards. To find out more about which certifications your product may have, please contact us.

* Ice production can change based on source water and ambient air temperature.