

Culligan. quench®

555-T

High-Capacity Sparkling Water Dispenser



- Cold and room temperature filtered water
- Chilled sparkling water
- Tap dispensing
- Ice bank cooling technology
- Space-saving countertop design





Specifications

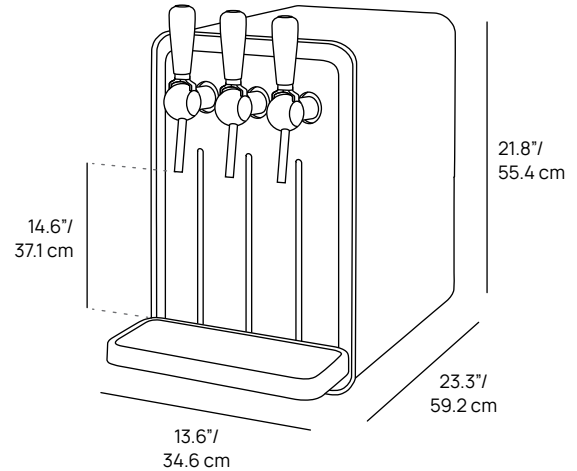

Product Details

Upgrade your commercial capacity filtered water dispenser with sparkling water! The 555-T is a contemporary commercial grade filtered still and sparkling water dispensing system. The 555-T offers a large dispensing area with tap dispensing, perfect for quick-filling large glasses and carafes. The 555-T has a cooling capacity of 20 gallons/75.8 liters per hour – that's six 8 oz. glasses every minute!

High-Capacity Sparkling Water Dispenser

- Cold and room temperature filtered water
- Chilled sparkling water
- Ice bank cooling technology
- Tap dispensing
- Dispensing height of 14.6"/37.1 cm to accommodate large glasses or carafes
- Safety inlet valve for quick shut-off
- Attractive stainless steel case

Dimensions	21.8" h x 13.6" w x 23.3" d / 55.4 cm h x 34.6 cm w x 59.2 cm d
Dispensing Area	14.6" / 37.1 cm
Weight	77 lbs
Water Options	Cold, room temperature, sparkling
Cooling Capacity	20 gallons per hour / 75.8 liters per hour
Cooling Technology	Ice bank
Operating CO ₂ Pressure	50 - 60 psi
Recommended Water Pressure	50 - 80 psi
Rated Voltage/Frequency	115V/60Hz
Power Consumption	330 W - 3.2 Amps
Model Number	555-T

Culligan Quench products are certified by independent authorized 3rd party laboratories in accordance of appropriate industry standards. To find out more about which certification your product may have, please contact us.

All sparkling water dispensers require CO₂ cylinders. If connecting to a bulk or existing CO₂ system, a CO₂ line terminating at a ¼" barbed shutoff valve must be available at the installation site.