

Culligan. quench®

150

Commercial Single-Cup Pod Brewer



- Advanced digital system
- Stainless steel carafe holds 60 oz.
- Pulse brewing technology
- Hot water spigot
- Energy Efficient





Specifications

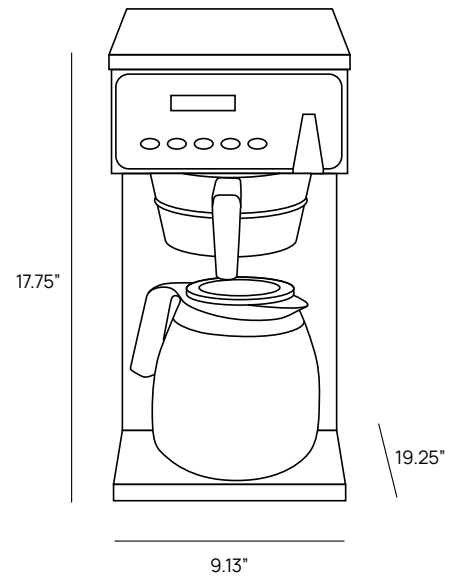

Product Details

Upgrade your office coffee brewer with the 150! This thermal coffee brewer holds up to 60 oz. of hot, fresh coffee in its stainless steel carafe for up to 6 hours. Using pulse brewing cycle technology, the 150 only brews when the water has reached optimum brewing temperature, enhancing the flavor in every ounce. The 150 is also equipped with a hot water spigot, perfect for tea, hot chocolate, and oatmeal. When not actively brewing, the 150 switches into energy-saving mode to reduce energy consumption.

Compact Thermal Coffee Brewer

- Advanced digital system with pulse brewing technology
- Stainless steel carafe holds 60 oz. of hot coffee for up to 6 hours
- Hot water spigot
- Energy efficient
- Uses freshly ground coffee

Dimensions	17.75" h x 9.13" w x 19.25" d depth measurement includes the hot water spigot lever
------------	---

Dispensing Area Height	8.13"
------------------------	-------

Weight	30 lbs
--------	--------

Rated Voltage/Frequency	120V/50/60Hz
-------------------------	--------------

Brew Capacity	60 oz. (pot is 64 oz.)
---------------	------------------------

Burst Capacity	4 gal/hr
----------------	----------

Water Source	1/4" Flare
--------------	------------

Must be installed within 25 feet of water source

Model	150
-------	-----

Uses freshly ground coffee

Culligan Quench products are certified by independent authorized 3rd party laboratories in accordance of appropriate industry standards. To find out more about which certifications your product may have, please contact us.